

FACE TO ME

Gebrauchsanweisung

Instructions for use

Mode d'emploi

Istruzioni per l'uso

**WICHTIG: SORGFÄLTIG LESEN
UND FÜR KÜNFTIGES NACH-
LESEN AUFBEWAHREN.**



GB

IMPORTANT:

RETAIN FOR FUTURE
REFERENCE. READ
CAREFULLY!

F

IMPORTANT:

A CONSERVER POUR
CONSULTATION
ULTERIEURE – A LIRE
SOIGNEUSEMENT!

I

ATTENZIONE:

CONSERVARE. LEGGERE
ATTENTAMENTE!



Lieferumfang / Delivery / Livraison / Volume di fornitura

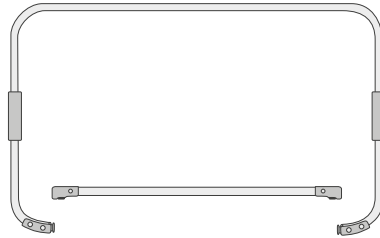
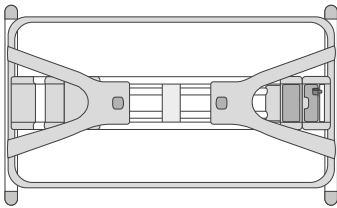
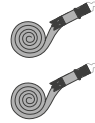
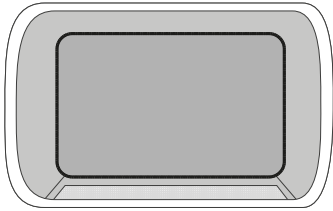

1

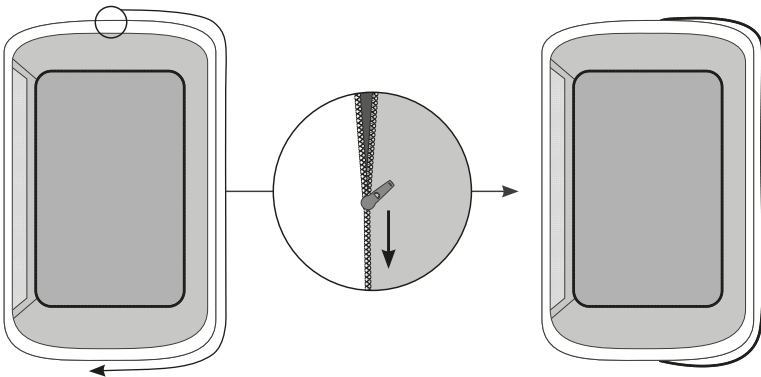
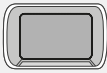

2

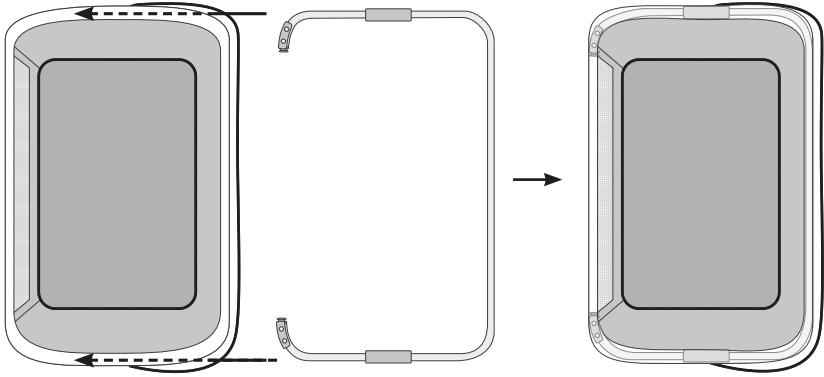

3

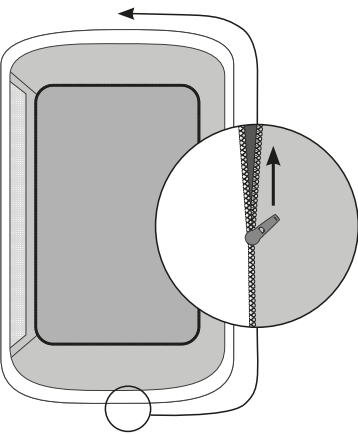
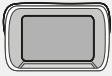

4

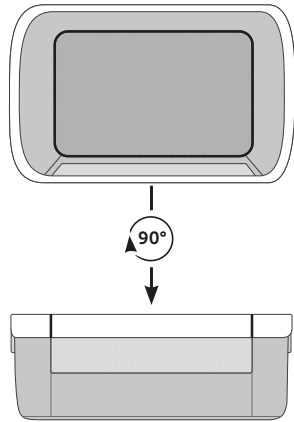
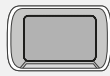

5

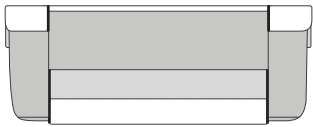
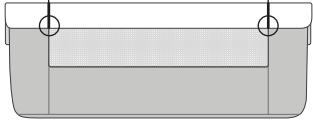
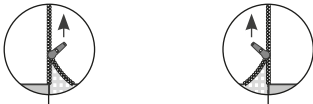

6

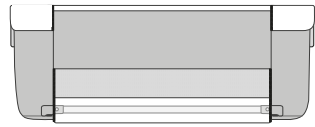
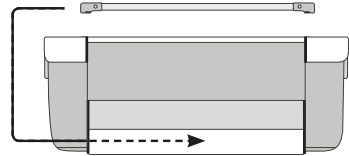
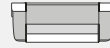

7

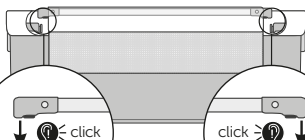
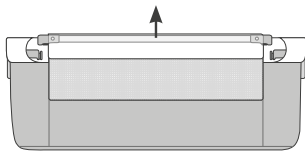

8

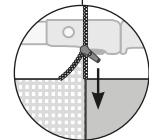
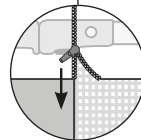

9

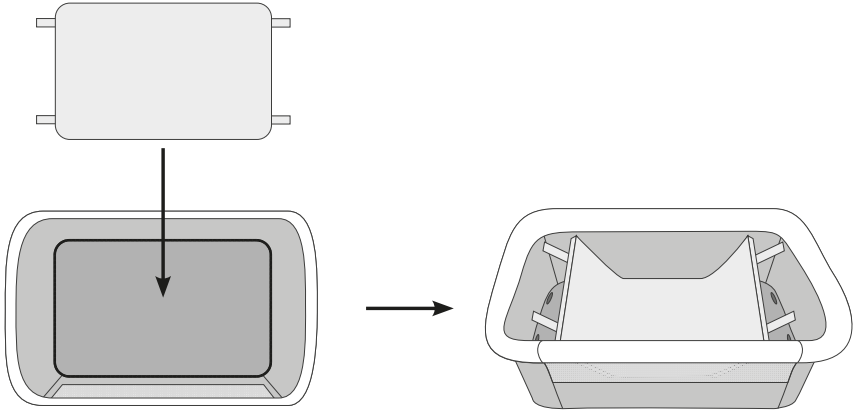

10

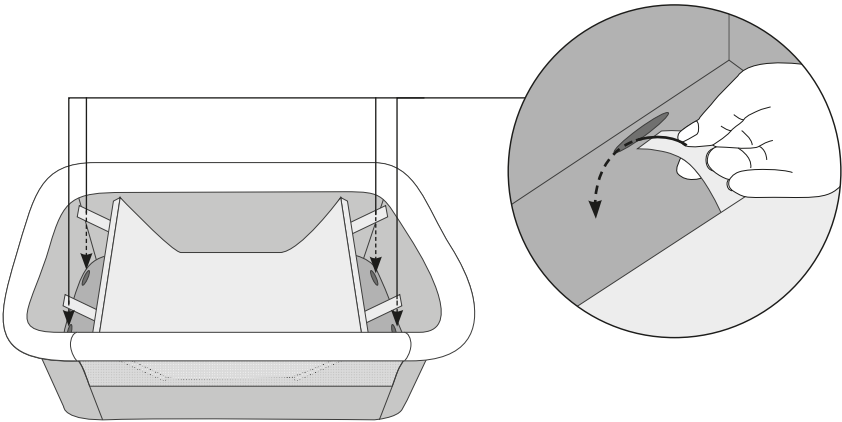

11

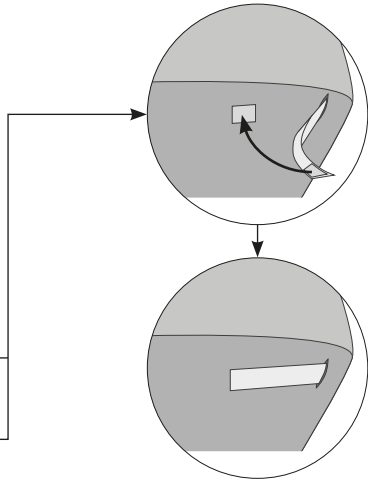
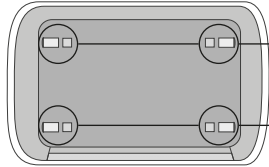
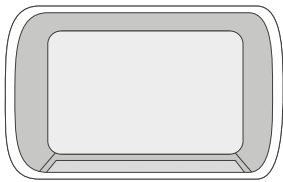
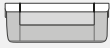

12

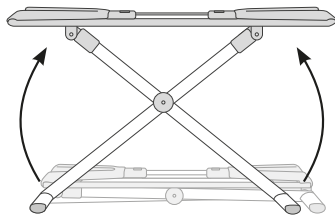
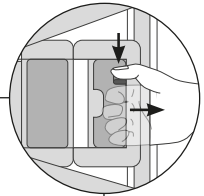
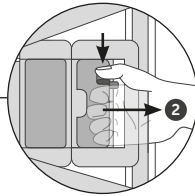
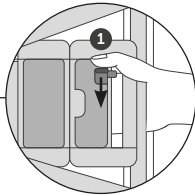
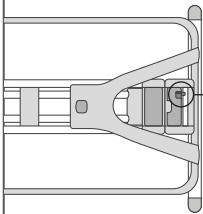
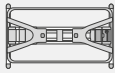

 click

13

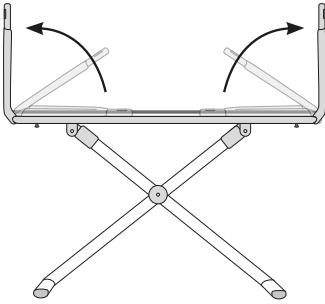

14

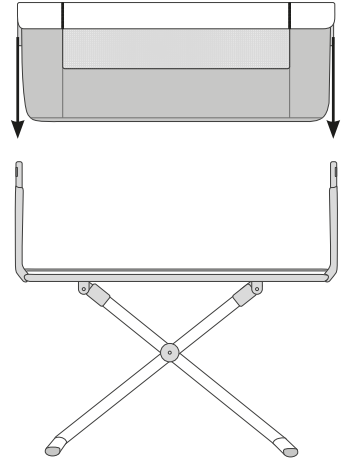

15

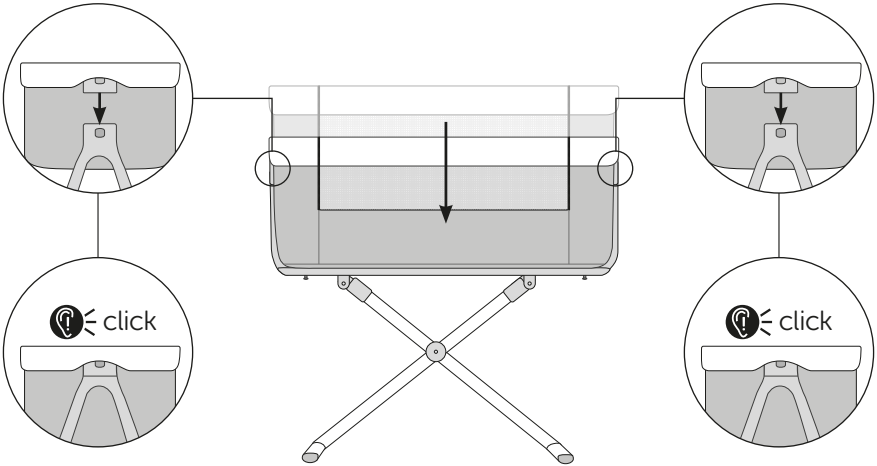

16

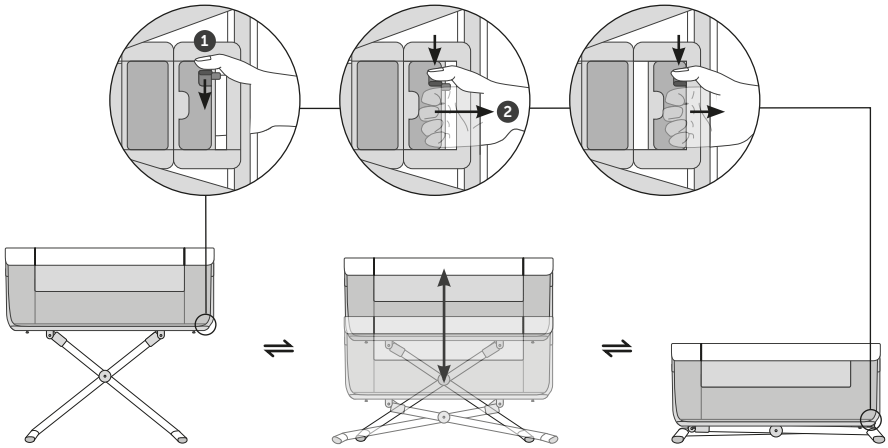

17

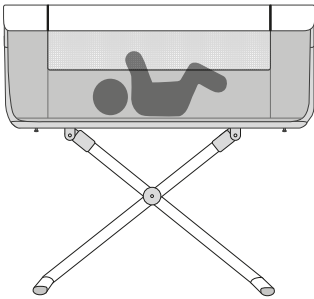

18

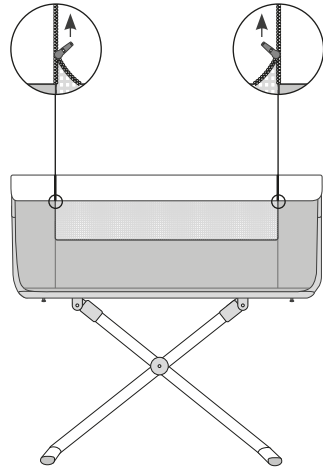

19

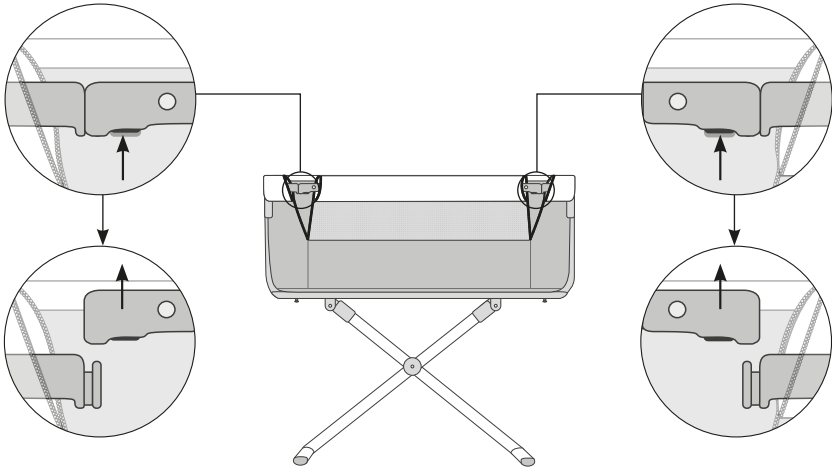

20

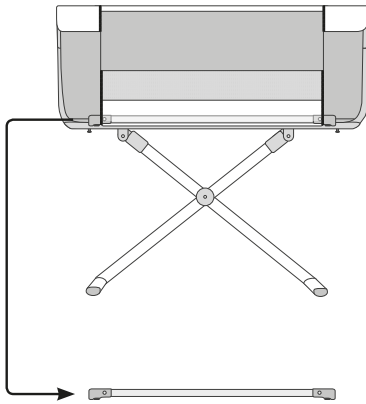

21

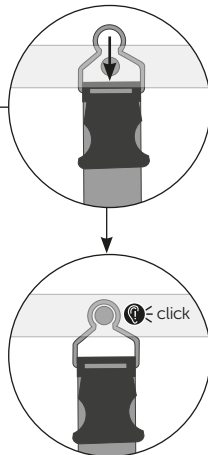
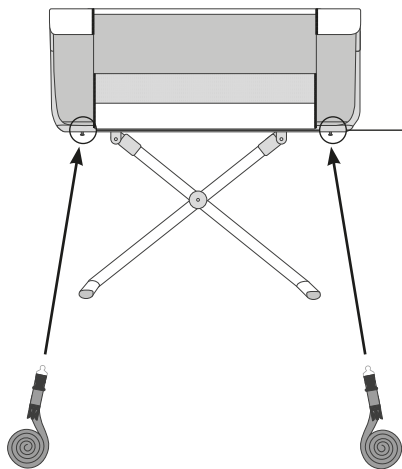

22



OPTION A

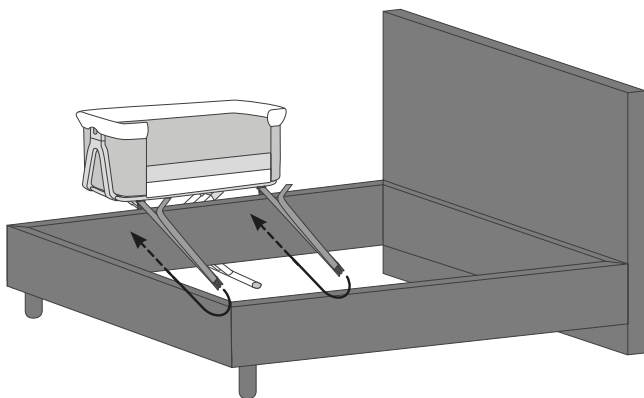

23



OPTION A

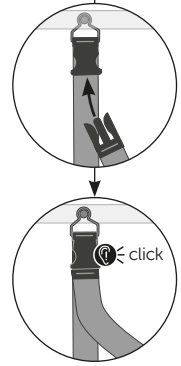
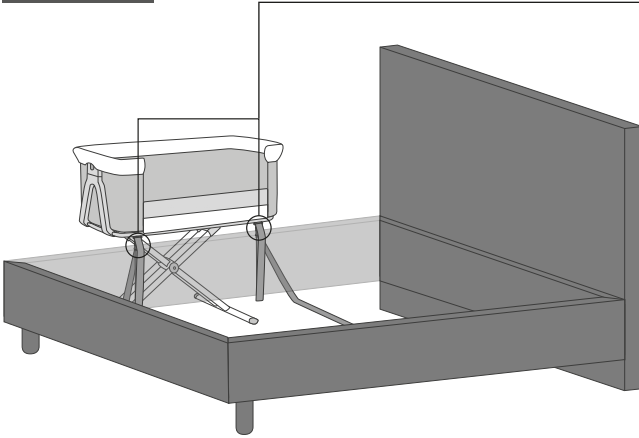

24



OPTION A

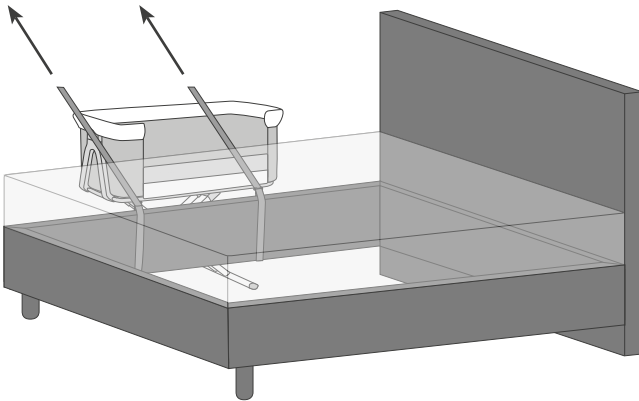

25



OPTION B

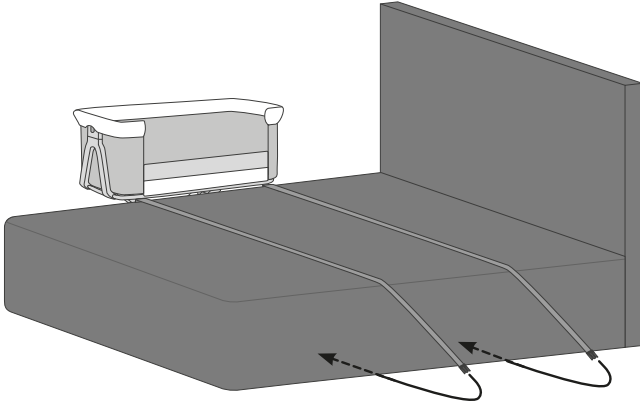

26



OPTION B

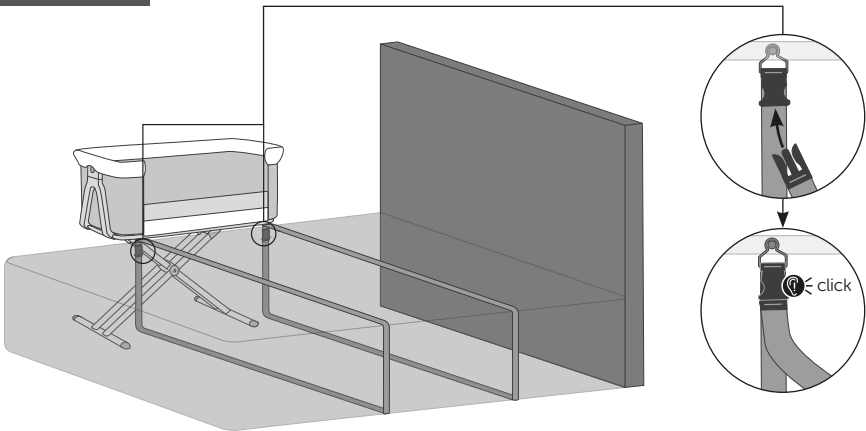

27



OPTION B

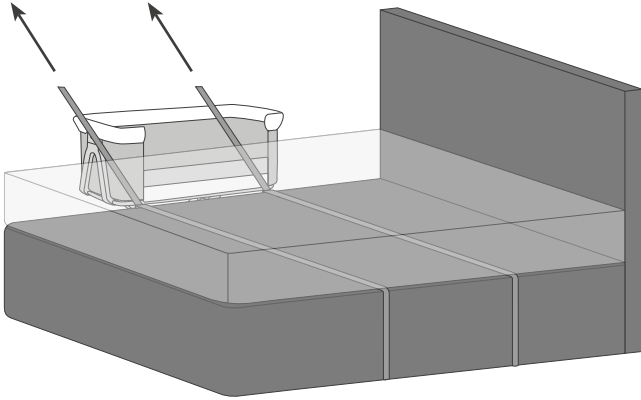

28



OPTION A

OPTION B

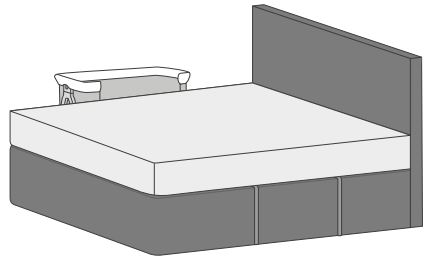
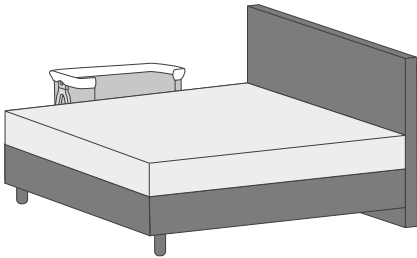

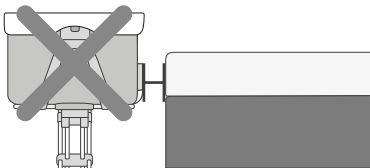
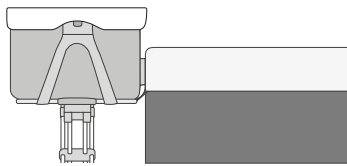
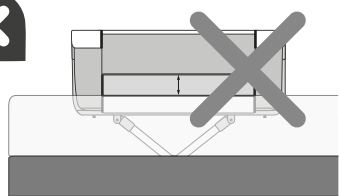
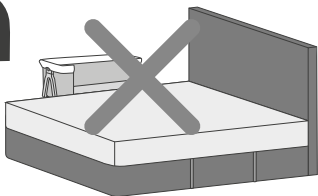
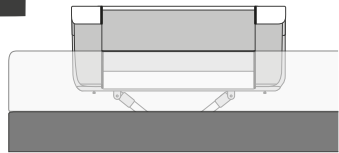
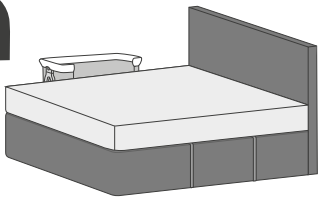

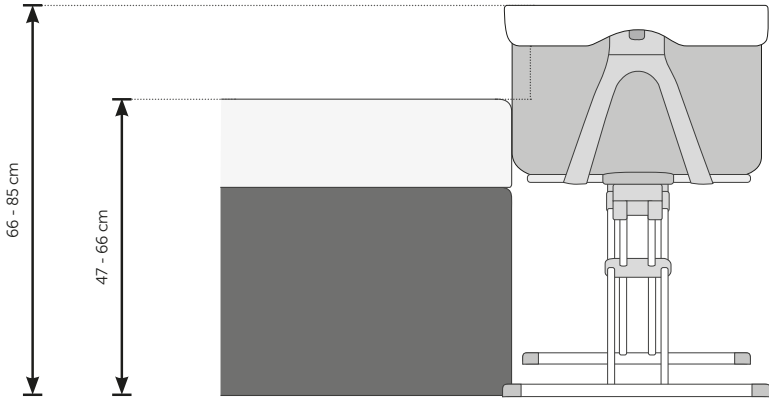

1

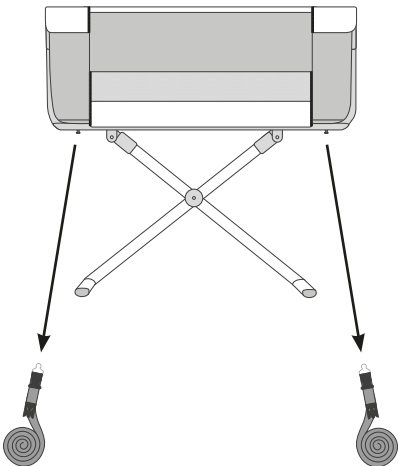

2

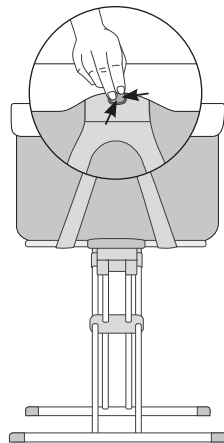

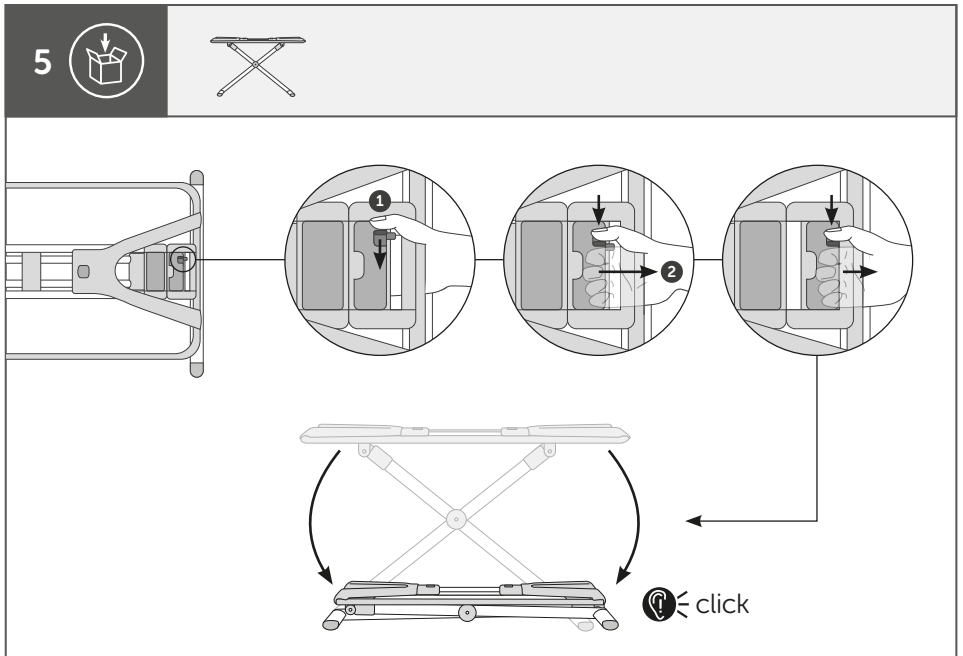
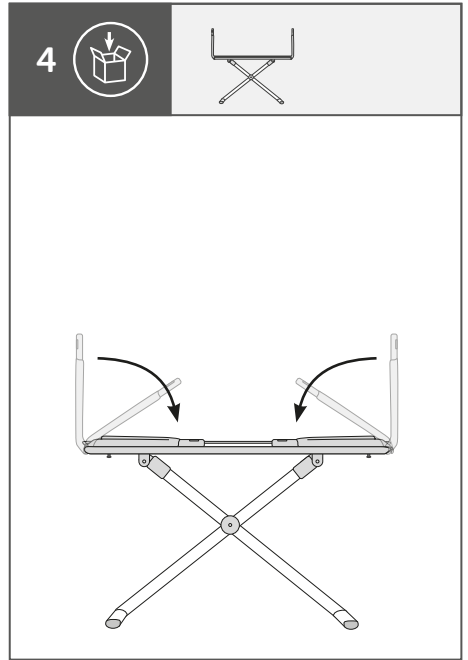
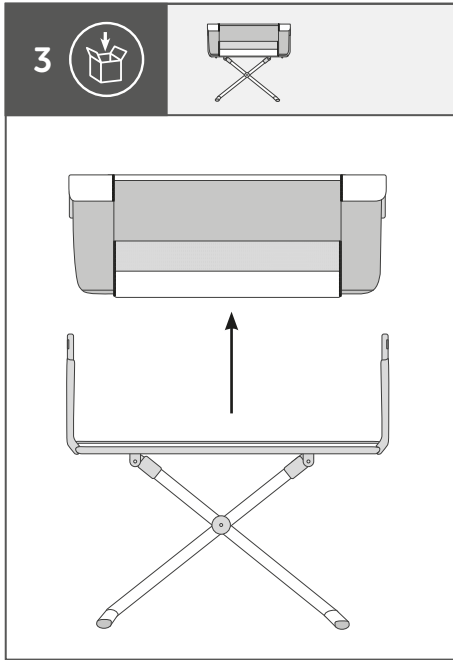

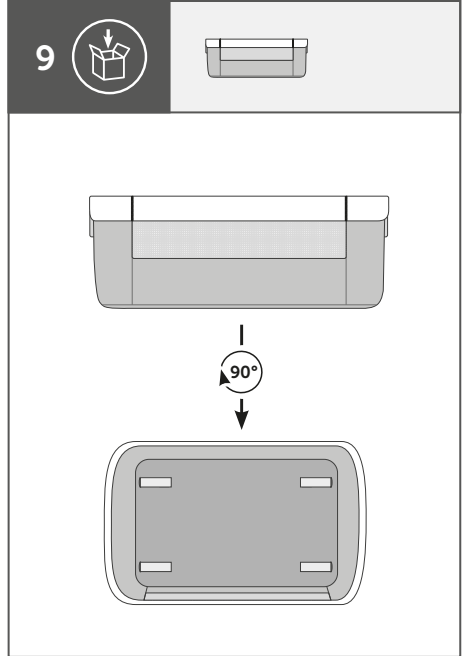
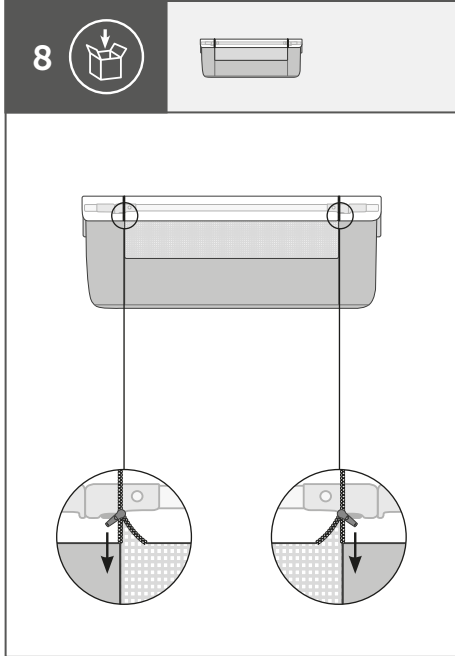
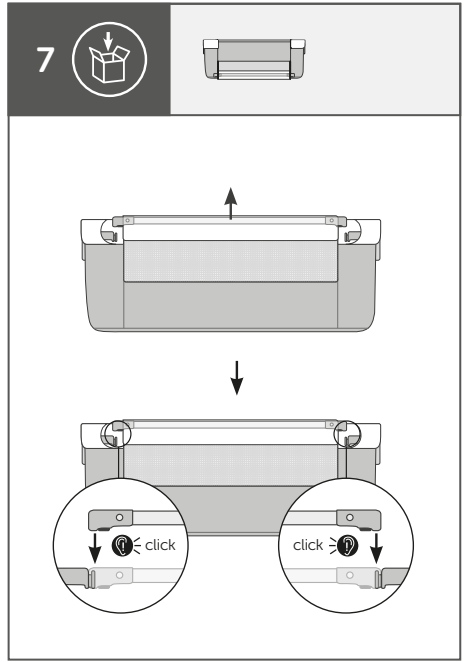
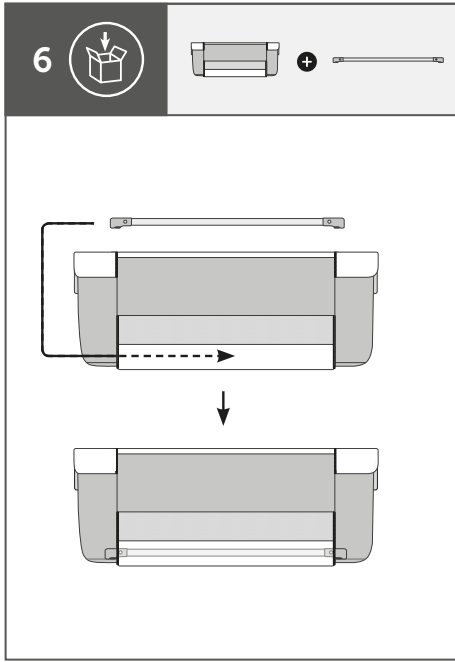

10

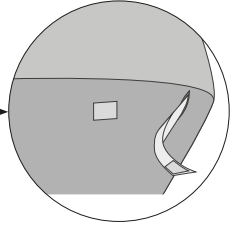
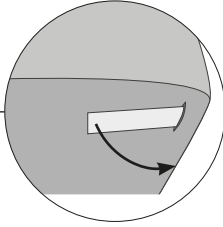
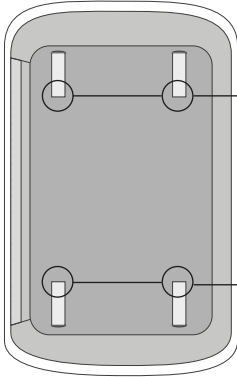
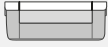

11

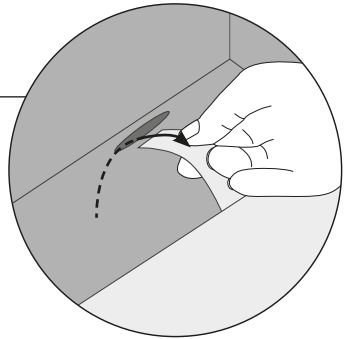
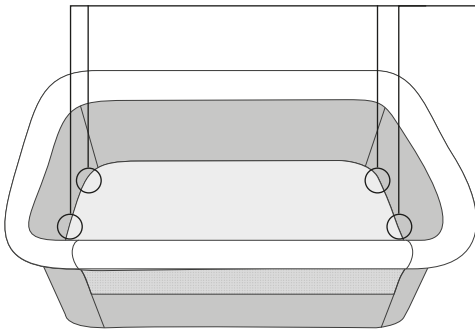

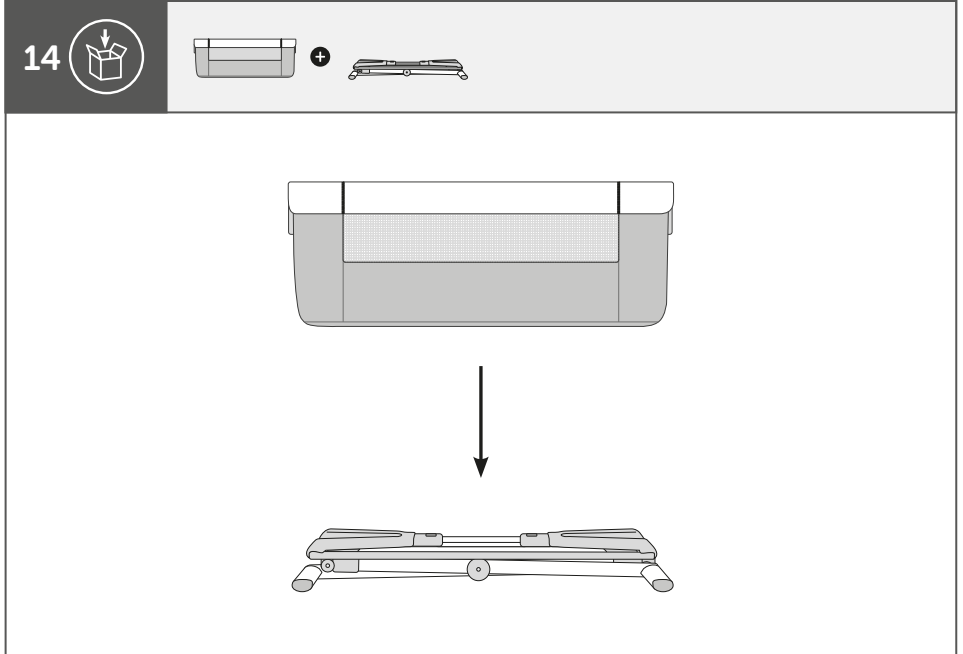
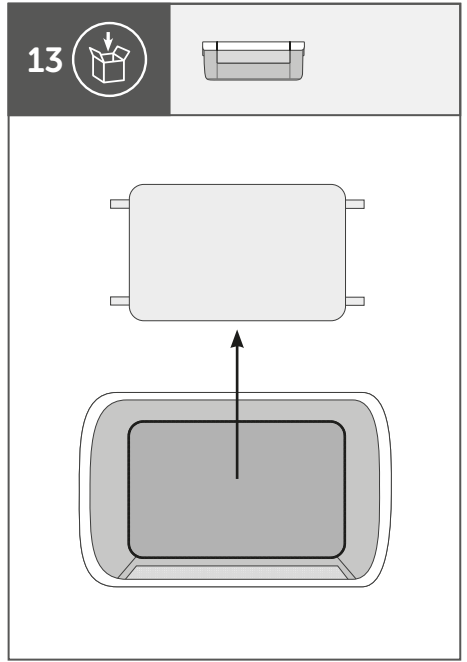
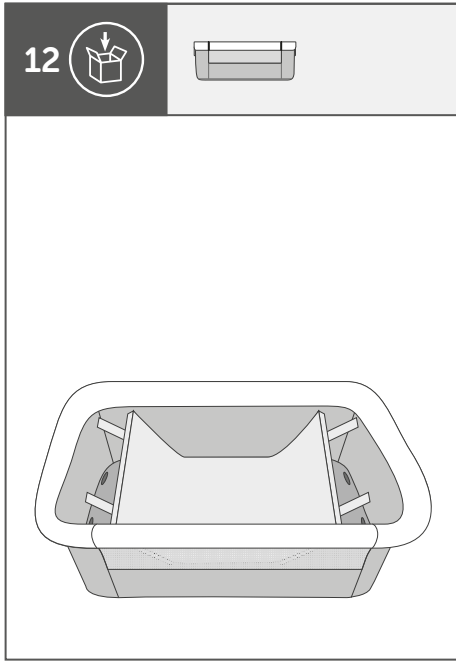

15

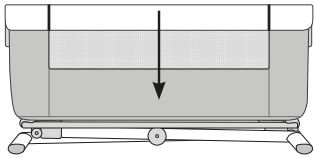

16

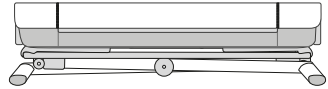

D WARNHINWEISE KRIPPEN UND WIEGEN

WARNUNG — Vor Gebrauch dieses Produkts die Anleitung lesen.

WARNUNG — Gebrauch dieses Produkts einstellen, sobald das Kind sitzen oder knien oder sich selbst hochziehen kann.

WARNUNG — Keine zusätzlichen Gegenstände (z. B. Spielzeug, Kissen...) in das Produkt legen.

WARNUNG — Das Produkt nicht in der Nähe eines anderen Produkts aufstellen, das eine Erstickungs- oder Strangulationsgefahr darstellen könnte, z.B. Schnüre, Rollo-/Gardinenschnüre usw.

WARNUNG — Nicht mehr als eine Matratze in dem Produkt verwenden.

WICHTIGE HINWEISE

- Die Krippe/Wiege muss auf horizontale Flächen gestellt werden.
- Kleine Kinder sollen nicht unbeaufsichtigt in der Nähe der Krippe/Wiege spielen.
- Die Krippe/Wiege muss in der festen Stellung gesichert sein, wenn das Kind unbeaufsichtigt in der Wiege liegt.
- Die Krippe/Wiege darf nicht benutzt werden wenn ein Teil zerbrochen, abgerissen ist oder fehlt. Verwenden Sie bitte nur HAUCK-Ersatzteile.
- Wenn das Kind sich aufsetzen, knien oder sich selbst hochziehen kann, darf die Krippe/Wiege für dieses Kind nicht mehr benutzt werden.
- Alle Beschlagteile müssen für die Montage immer sachgemäß befestigt sein. Schrauben dürfen nicht locker sein, da sich das Kind daran klemmen könnte oder Kleidungsstücke (z.B. Kordeln, Halsbänder oder Bänder für Schnuller usw.) hängenbleiben könnten und sich damit die Gefahr einer Strangulierung ergibt.
- Stellen Sie die Krippe/Wiege nicht in die Nähe von offenen Feuern oder anderen starken Hitzequellen wie elektrischen Heizstrahlern, Gasöfen usw.
- Krippe NICHT verwenden, wenn ein beliebiges Teil fehlt, beschädigt oder gebrochen ist. Im Bedarfsfall HAUCK hinsichtlich Ersatzteilen und Anleitungen kontaktieren. KEINE behelfsmäßigen Teile verwenden.
- prEN 1130

PFLEGE UND WARTUNG

- Bitte beachten Sie die Textilkennzeichnung.
- Reinigen, pflegen und kontrollieren Sie dieses Produkt regelmäßig.

GB WARNINGS CRIBS AND CRADLES

WARNING! – Do not use this product without reading the instructions first.

WARNING! – Stop using the product as soon as the child can sit or kneel or pull itself up.

WARNING! – Do not place additional items (e.g. toys, pillows...) in the product.

WARNING! – Do not place the product close to another product, which could present a danger of suffocation or strangulation, e.g. strings, blind /curtain cords, etc.

WARNING! – Do not use more than one mattress in the product.

IMPORTANT INFORMATION

- The cradle should only be placed on an horizontal surface.
- Young children should not be allowed to play in the vicinity of a crib or cradle.
- Do not use the product if any part is broken, torn or missing. Please use only HAUCK spare parts.
- When a child is able to sit, kneel or pull itself up, the crib or cradle shall not be used anymore for this child.
- All assembly fittings should be always tightened and care should be taken that no screws are loose, because a child could trap parts of the body or clothing (e.g. strings, necklaces ribbons for babies dummies, etc.) which would pose a risk of strangulation.
- Be aware of the risk of open fires and other sources of strong heat, such as electric bar fires, gas fires, etc. in the near vicinity of the crib or cradle.
- DO NOT use the product if any parts are missing, damaged, or broken. Contact HAUCK for replacement parts and instructional literature if needed. DO NOT substitute parts.
- prEN 1130

CARE AND MAINTENANCE

- Please heed the textile care symbols.
- Please clean, maintain and check this product regularly.

F AVERTISSEMENTS BERCEAUX

ATTENTION - N'utiliser pas le produit avant lire le mode d'emploi.

ATTENTION - Cesser d'utiliser ce produits lorsqu'un enfant peut s'asseoir, s'agenouiller ou se lever tout seul.

ATTENTION - Ne mettre pas d'autres objets (par ex. jouets, coussin...) dans le produit.

ATTENTION - Ne placer pas le produit dans la proximité d'un produit qui représente un danger d'étouffement ou de strangulation, par ex. fils, persienne/ filets de rideau etc.

ATTENTION - N'utiliser pas plus d'un matelas dans ce produit.

INFORMATIONS IMPORTANTES

- Il convient de placer le berceau sur un sol horizontal.
- Il convient de ne pas autoriser les jeunes enfants à jouer sans surveillance à proximité d'un berceau.
- Le berceau ne doit pas être utilisé si une pièce quelconque est cassée, déchirée ou manquante. Utiliser seulement pièces de rechange de HAUCK.
- Lorsqu'un enfant peut s'asseoir, s'agenouiller ou se lever tout seul, le berceau ne doit plus être utilisé pour cet enfant, s'il vous plaît.
- Les dispositifs d'assemblages doivent toujours être convenablement serrés, un soin particulier doit être apporté au fait que les vis ne soient pas desserrées, car un enfant pourrait accrocher une partie de son corps ou de son vêtement (par exemple des cordons, des colliers, des rubans pour sucettes à bébé) ce qui présenterait un danger d'étranglement.

- Pour prévenir tout risque de déclenchement d'incendie, éviter toute source de chaleur et d'autres sources de forte chaleur, comme les appareils de chauffage électrique, les appareils de chauffage à gaz,...dans le proche voisinage du berceau.
- N'utiliser pas le berceau si une pièce quelconque est cassée, déchirée ou manquante. Si nécessaire, contacter HAUCK en ce qui concerne pièces de rechange e mode d'emploi. PAS utiliser pièces provisoires.
- prEN 1130

ENTRETIEN ET MAINTENANCE

- Veuillez tenir compte de l'étiquette textile.
- Nettoyez, entretenez et contrôlez ce produit à intervalles réguliers.

I AVVERTENZE CULLE

ATTENZIONE - Non usare la culla avanti di aver letto le istruzioni per l'uso.

ATTENZIONE - Smettere di usare la culla appena il bambino sà stare seduto o inginocchiato o alzarsi tutto solo.

ATTENZIONE - Non mettere ulteriori oggetti (giocattoli, cuscini...) all'interno del prodotto.

ATTENZIONE - Non montare il prodotto nelle vicinanze di un'altro prodotto che potrebbe rapresentare un pericolo di soffocazione, come per esempio fili, fili di tendaggi ecc.

ATTENZIONE - Non mettere mai più di un materasso nella culla.

INFORMAZIONI IMPORTANTI

- Il lettino deve essere montato su una superficie orizzontale.
- Ai bambini piccoli non deve essere permesso di giocare nelle vicinanze di una culla senza sorveglianza.
- Non utilizzare il prodotto se esso o una parte di esso è rotta, rovinata o mancante. Utilizzare solamente pezzi di ricambio di HAUCK.
- Appena un bambino riesce a sedersi, inginocchiarsi o alzarsi, il lettino o culla non deve più essere utilizzato per questo bambino.
- Tutte le parti di assemblaggio devono essere sempre avvitate e si deve poi fare attenzione che nessuna vite sia allentata, perché parti del corpo o dell'abbigliamento del bambino potrebbero impigliarsi (ad es. stringhe, collane, nastri ecc.), rischiando di causare strangolamento.
- Non mettere la culla nelle vicinanze di fiamme libere e forti fonti di calore, come caminetti elettrici, caminetti a gas ecc.
- NON utilizzare il lettino se esso o una parte di esso è rotta, rovinata o mancante. Se necessario, contattare HAUCK in riguardo a pezzi di ricambio o istruzioni per l'uso. NON utilizzare pezzi provvisori.
- prEN 1130

CURA E MANUTENZIONE

- Osservare il contrassegno sul tessuto
- Pulire, mantenere e controllare questo prodotto regolarmente.

D WARNHINWEISE BEISTELLBETTEN

WARNUNG — Zur Vermeidung von Gefährdungen durch das Fangen des Kinderhalses am oberen Geländer des am Erwachsenenbett befindlichen Seitenteils darf dieses Geländer nicht höher als die Matratze des Erwachsenenbettes sein.

WARNUNG — Zur Vermeidung von Gefährdungen durch Aufwickeln muss das Verbindungssystem mit dem Erwachsenenbett stets fern und außerhalb der Krippe gehalten werden.

WARNUNG — Ein Beistellbett darf **NUR** verwendet werden, nachdem es sicher mit dem Erwachsenenbett verbunden ist oder das herunterklappbare Seitenteil vollständig hochgeklappt ist, um das Fallen des Kindes aus der Höhe zu verhindern.

WICHTIGE HINWEISE

- Beistellbetten dürfen niemals in geneigter Stellung verwendet werden.
- Bei Verwendung als Beistellbett müssen die mitgelieferten Gurte benutzt werden. Beistellbett NICHT verwenden, wenn ein beliebiges Teil fehlt, beschädigt oder gebrochen ist. Im Bedarfsfall HAUCK hinsichtlich Ersatzteilen und Anleitungen kontaktieren. KEINE behelfsmäßigen Teile verwenden.
- Das Beistellbett ist geeignet für Erwachsenenbetten mit einer Höhe von 47 - 66 cm über dem Boden.
- Zur Verhinderung einer Gefährdung durch äußeres Ersticken aufgrund von Fangen muss das Beistellbett ordnungsgemäß unter Verwendung des Verbindungssystems sicher am Erwachsenenbett befestigt sein.
- Zwischen der Unterseite des Beistellbettes und der Matratze des Erwachsenenbettes darf niemals ein Zwischenraum sein.
- Der Befestigungszustand des Verbindungssystems soll vor jedem Gebrauch geprüft werden, indem das Beistellbett in eine Richtung weg vom Erwachsenenbett gezogen wird.
- Produkt NICHT verwenden wenn ein Zwischenraum zwischen Beistellbett und Erwachsenenbett vorhanden ist. Zwischenräume sollten nicht mit Kissen, Decken oder anderen Gegenständen geschlossen werden.

GB WARNINGS BEDSIDE SLEEPERS

WARNING! – To avoid hazards from the child's neck being caught on the top rail on the side that is next to the adult bed, the top rail must not be higher than the adult bed mattress.

WARNING! – To avoid entanglement hazards the attachment system to the adult's bed shall always be kept away from and out of the crib.

WARNING! – A bedside sleeper shall **ONLY** be used once it has been securely attached to the adult's bed or when the drop side is in the fully raised position to prevent the child falling from height.

IMPORTANT INFORMATION

- Bedside sleepers shall never be used in an inclined position.
- When using the bedside sleeper, the fixing straps included in delivery must be used. DO NOT use bedside sleeper if any parts are missing, damaged, or broken. Contact HAUCK for replacement parts and instructional literature if needed. DO NOT makeshift parts.
- The bedside sleeper is adapted for use with adult beds with a height of 47 - 66 cm over the soil.
- To prevent a suffocation hazard from entrapment, the bedside sleeper shall be properly secured to the adult bed using the attachment system.
- There must never be a gap between the lower side of the bedside sleeper and the mattress of the adult bed.
- Check the tightness of the attachment system before each use by pulling the bedside sleeper in a direction away from adult bed.
- If there is any gap between the bedside sleeper and the adult bed DO NOT use product. Gaps should not be filled with pillows, blankets or other items.

F AVERTISSEMENTS LIT PARAPLUIE

ATTENTION - Pour éviter danger d'avoir le cou de l'enfant captivé à la partie supérieure qui se trouve à côté du lit des adults, cette partie ne doit jamais être plus haute du matelas du lit des adults.

ATTENTION - Pour éviter danger d'être enroulé, le système de connexion doit être rangé toujours à l'extérieur et loin du lit parapluie.

ATTENTION - Un lit parapluie peut être utilisé SEULEMENT après être connecté en manière sûre avec le lit des adults ou quand la partie latérale est complètement fermée vers le haut, pour éviter que l'enfant tombe du lit.

INFORMATIONS IMPORTANTES

- Les lit parapluie ne doivent jamais être utilisés en position inclinée.
- Pour l'utilisation du lit d'appoint, les sangle doivent être utilisées. PAS utiliser le lit si une pièce quelconque est cassée, déchirée ou manquante. PAS utiliser de pièces provisoires.
- Le lit est adapté pour l'usage avec des lits d'adultes avec une hauteur de 47 - 66 cm à partir du sol.
- Pour éviter les dangers de suffocation causés par être captivé entre les lits, le lit parapluie doit être fixé en bonne et due forme avec le système de connexion au lit des adults.
- Entre le dessous du lit parapluie et le matelas du lit des adults ne doit jamais être un interval.
- La condition de fixation du système de connexion doit être vérifié avant chaque usage en tirant le lit parapluie loin du lit des adults.
- PAS utiliser le produit en cas d'un interval entre le lit parapluie et le lit des adults. Ne fermer pas cet interval avec des coussins, couettes ou autre objets.

I AVVERTENZE LETTINI DA VIAGGIO

ATTENZIONE - Per evitare che il collo del bambino sia messo in pericolo alla parte superiore della parte laterale che si trova al letto dei genitori, questa parte non deve superare l'altezza del materasso del letto dei genitori.

ATTENZIONE - Per evitare pericoli di essere avvolto, il pezzo di connessione per il letto dei genitori deve essere fuori dalla presa dei bambini all'interno del lettino.

ATTENZIONE - Un lettino come questo deve essere utilizzato **SOLO** una volta che è stato sicuramente connesso con il letto dei genitori o quando la parte laterale è completamente chiusa verso l'alto, per evitare che il bambino cade.

INFORMATIONS IMPORTANTES

- I lettini non devono essere mai utilizzati in posizione inclinata.
- Per l'uso di un lettino in combinazione al letto da adulti devono essere utilizzate le cinghie in dotazione. **NON** utilizzare il lettino in caso di una parte mancante, danneggiata o rotta. In caso di necessità, rivolgersi a HAUCK in riguardo a pezzi di ricambio e istruzioni per l'uso. **NON** utilizzare pezzi provvisori.
- Il lettino è adatto per letti da adulti con un'altezza di 47 - 66 cm a partire dal pavimento.
- Per evitare pericoli di soffocamento causati dall'essere presi nel lettino, il lettino deve essere fissato in modo sicuro e secondo le istruzioni tramite il sistema di connessione.
- Entro la parte sottoriore del lettino e il materasso del letto da adulti non deve essere mai una distanza.
- La condizione del fissaggio del sistema di connessione deve essere controllato avanti ogni uso tirando il lettino via dal letto da adulti.
- **NON** utilizzare il prodotto in caso di una distanza fra il lettino e il letto da adulti. Queste distanze non devono essere chiuse con cuscini, coperte o altri oggetti.



hauck GmbH + Co. KG
Frohnlicher Str. 8
96242 Sonnefeld
Germany

phone: +49(0)9562/986-0
fax: +49(0)9562/6272
mail: info@hauck.de
web: <http://www.hauck.de>